



LINK-IT 2 (1x INPUT + 1x OUTPUT GSM)

The **SENTRY™ LINK-IT 2** is a cost effective but versatile IoT (*Internet of Things*) solution for various remote automation projects. Multiple users WEB and APP controlled. SMS control is available as well. It provides one digital Input (configurable by polarity of triggering) and one relay Output (active state settable to Low or High plus NO and NC free potential contacts). There is an option to logically “link” the input to the output i.e. the certain state of the input automatically sets a predefined state of the output.



FEATURES

- ONE digital input and ONE Relay output (NO and NC contacts)
- Input is configurable by polarity of triggering
- Output can be set to Pulse, Latch or Toggle mode
- Output control by missed call
- WEB, Smart phone APP and SMS control
- Works with any GSM network operator SIM card (provided by the user)
- Internal / External GSM Antenna variants
- Up to **2000 Access users**
- Up to **100 SMS Alert destinations**
- Up to **10 SMS Report destinations**
- Low Power supply voltage alert

TECHNICAL SPECIFICATIONS

SPECIFICATIONS:

- Power supply voltage: min. 12VDC / max. 24VDC
- Input voltage range: min. 3VDC / max. 24VDC
- Supply Current: max. 80mA when relay output is latched ON
- Relay output contacts: rated up to 5A / 250VAC / 50 or 60Hz
- Dimensions: 160x60x45mm
- Weight: ±110g
- IP rating: IP55
- Operating temperature: -10°C to +55°C
- Operating humidity: <80%



DO NOT EXCEED RELAY RATINGS
4A max. (RESISTIVE LOADS)
2A max. (INDUCTIVE LOADS)



ELECTRICAL CONNECTIONS

Electrical Schematic Diagram

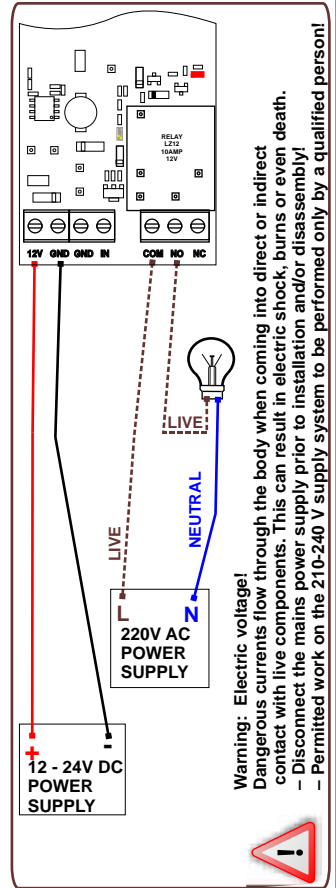
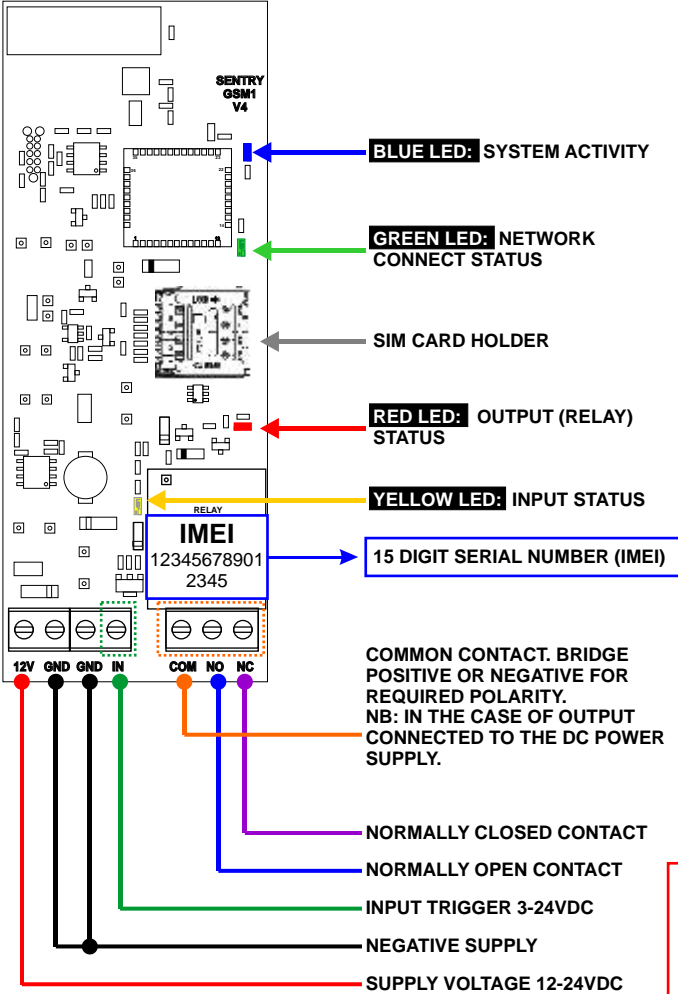

Handle with care.
 Do not touch the electronic components.
 Hold on the sides of the PC Board.
 Electrostatic Sensitive Device

EXAMPLE

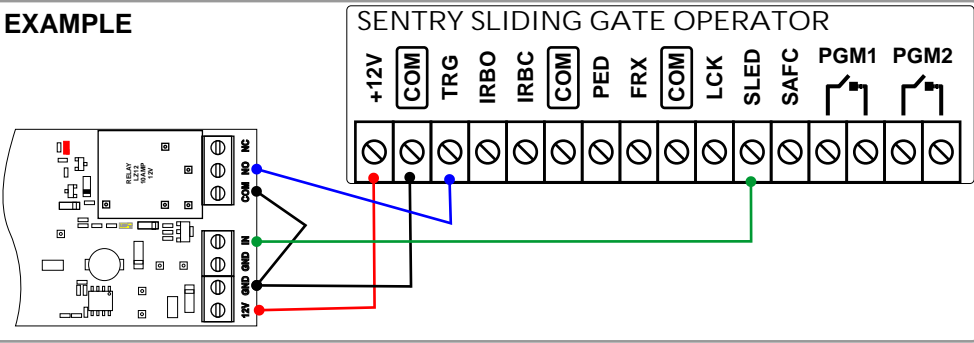

- Purchase and RICA a SIM card. (Use a preferred Network for your area.)
- Insert the SIM card into a mobile phone to activate. Insure that the caller line identification (CLI) and GPRS setting are enabled. **(NB: This is to allow for access to our WEB and Sentry APP platforms.)**
- Load SMS bundle (for SMS control) or/and data bundle (for WEM or APP control).
- Save the mobile number of the SIM card.
- Insert SIM card into the SIM card holder of the Sentry Link-It unit.
- Connect voltage, relay output and/ or input as required. (Refer to page 2, ELECTRICAL CONNECTIONS)
- Power up the unit. The **green LED** will start flashing, indicating that the unit is trying to connect to the GSM network.
- Once the **green LED** stays on steady the unit has connected to the network. The **blue LED** will also flash, indicating that the unit is now operational.
- **Set up the unit using the SMS COMMANDS.**
- Set **SMS acknowledgment** (recommended). Section 1.5 (pg. 4)
- **Change the password** (recommended). Section 1.1 (pg. 3)
- Set **site name ID** (optional). Section 1.4 (pg. 3)
- Setup **relay output**.
- Set **output mode**. This sets the relay to **Latch, Pulse or Toggle. Default is 'Pulse'**. Section 4.2 (pg. 5)
- Set **output active on time. Only applicable in PULSE or TOGGLE mode**. Section 4.3 (pg. 6)
- Set **output alert SMS option** (optional). This will notify you via SMS if the state of the output changes. Section 4.6 (pg. 6)
- Setup **input state** (if required). **Default is 'Positive'** Section 3.1 (pg. 5)
- **Add users**. This sets up the mobile phone numbers to activate the unit. Section 2.1 (pg. 4)
- **NB: Users can change the status of the output via SMS or Missed call!**
- User numbers can also be added using our Web platform. See below.

• If you have any questions or would like a full pdf version manual, please send your request to technical@martin-electronics.co.za .

USING THE WEB PLATFORM

** The web platform is used for adding or removing user phone numbers.

- Log into the Sentry Web portal. sentryweb.martin-electronics.co.za
- Create a user name and password.
- Follow the web platform help

Note: Device ID (IMEI) is on the relay of the unit.

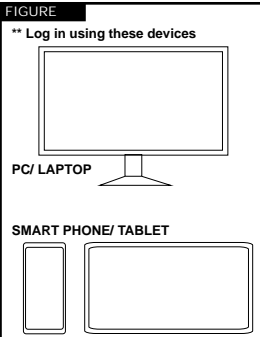

SMS Command Format + (Example)	Description	Accepted parameters	Response SMS - (ACK) means that response is sent ONLY when sack is set to 1.
1. SYSTEM SETUP 1.1 SET DEVICE NEW PASSWORD **ppppppp *spw*pppppppp E.g.: **password*spw*MyPsw951	Stores a NEW Password <P> for device access. Password is MIN 4, MAX 8 characters, letters and digits ONLY, Case-Sensitive. The default password is password .	Password size P must be (4<= P <=8) characters.	IF SUCCESS: "[DT+SITE_NAME] - NEW password saved!" (ACK) IF FAILED: "[DT+SITE_NAME] - NEW password write ERROR!" (ACK)
1.2 ENTER SPECIAL PASSWORD TO RESET THE PASSWORD TO "password" *cccccccccccccc* *spsr E.g.: **124ed6792abc987*spsr	Resets module Password to the default value of "password". Special 15 character Password<C>, provided by SENTRY must be entered. NB: Case-sensitive!	Special string C = 15 characters	IF SUCCESS: "[DT+SITE_NAME] - Password defaulted to "password!" IF FAILED: "[DT+SITE_NAME] - Password default ERROR!"
1.3 CLEAR ALL SETTINGS TO THEIR DEFAULT VALUES **pppppppp *sclr	Resets ALL Info and Settings of the module to their respective default values.	N/A	IF SUCCESS: "[DT+SITE_NAME] - ALL settings cleared to the default values!" IF FAILED: "[DT+SITE_NAME] - DEFAULT of all settings FAILURE!"
E.g.: **Password*sclr			
1.4 SET SITE TEXT ID NAME **pppppppp *ssid*cccccccccccccccccccccccccccccccccccc E.g.: **password*ssid*My SENTRY GSM	Sets the Text string <C> that will be displayed at the top of each incoming SMS, can be used to identify the site/location of the unit. The default site name is GSM Control .	Text string C <= 30 characters	IF SUCCESS: "[DT+SITE_NAME] - NEW device name saved!" (ACK) IF FAILED: "[DT+SITE_NAME] - NEW device name write ERROR!" (ACK)

SMS Command Format + (Example)	Description	Accepted parameters	Response SMS - (ACK) means that response is sent ONLY when sack is set to 1.
2->ADD/REMOVE/ CHECK USER		Phone number D = 20 digits	IF SUCCESS: "[DT+SITE_NAME] - User <PHONE_NUMBER> confirmed!"
2.3 CHECK IF USER PHONE NUMBER WAS PREVIOUSLY STORED	Checks if a particular Phone number <D> is stored in the User table. The phone number must be in a valid format.	Input number N = (1...8) If Active High -> S = 1 If Active Low -> S = 0	IF FAILED: "[DT+SITE_NAME] - User <PHONE_NUMBER> NOT FOUND!"
E.g.: **password*uchk*+27739876543			
3-> INPUT SETUP		Input number N = (1...8) If Active High -> S = 1 If Active Low -> S = 0	IF SUCCESS: "[DT+SITE_NAME] - Input <N> ACTIVE state set to [HIGH or LOW]" (ACK) IF FAILED: "[DT+SITE_NAME] - Input <N> ACTIVE state write ERROR!" (ACK)
3.1 SET INPUT ACTIVE STATE	Sets Input <N> Active state <S> High or Low	Input number N = (1...8) If Active High -> S = 1 If Active Low -> S = 0	IF SUCCESS: "[DT+SITE_NAME] - Input <N> ACTIVE state set to [HIGH or LOW]" (ACK) IF FAILED: "[DT+SITE_NAME] - Input <N> ACTIVE state write ERROR!" (ACK)
E.g.: **password*iact*1*1	The default setting is Active High (1) .		
3.2 SET INPUT ACTIVE DELAY	The Time <T> in increment of 100ms for which Input <N> must be in changed state before it is recognised by the unit.	Input number N = (1...8) Time T = (1...250) in increments of 100ms	IF SUCCESS: "[DT+SITE_NAME] - Input <N> change confirmation TIME set to <T>ms!" (ACK) IF FAILED: "[DT+SITE_NAME] - Input <N> change confirmation TIME write ERROR!" (ACK)
E.g.: **password*ihld*1*5	The default setting is 500ms (5) .		
3.3 SET INPUT CHANGE ALERT OPTION	Sets whether or not a SMS Alert is sent when input<N> is changed. The alert is sent to ALL Alert Destinations .	Input number N = (1...8) If Alert NOT sent -> S = 0 If Alert sent ONLY on input change to ACTIVE -> S = 1 If Alert sent ONLY on input change to INACTIVE -> S = 2 If Alert sent on ANY input change -> S = 3	IF SUCCESS: "[DT+SITE_NAME] - Input <N> change state SMS ALERT [ON or OFF]" (ACK) IF FAILED: "[DT+SITE_NAME] - Input <N> change state SMS ALERT write ERROR!" (ACK)
E.g.: **password*ialt*1*1	The default setting is Alert NOT sent (0) .		
3.4 SEND SMS TEXT WHEN INPUT IS TRIGGERED	Sets the SMS Text string <C> that the device will send to ALL Alert Destinations when Input <N> changes to State <S>.	Sets the SMS Text string <C> that the device will send to ALL Alert Destinations when Input <N> changes to State <S>.	Sets the SMS Text string <C> that the device will send to ALL Alert Destinations when Input <N> changes to State <S>.
E.g.: **password*itxt*1*1*Pump ON	The default setting are: Input <N> ON and Input <N> OFF .	The default setting are: Input <N> ON and Input <N> OFF .	The default setting are: Input <N> ON and Input <N> OFF .
4-> OUTPUT SETUP		Output number N = (1...8) If Active High -> S = 1 If Active Low -> S = 0	IF SUCCESS: "[DT+SITE_NAME] - Output <N> ACTIVE state set to [HIGH or LOW]" (ACK) IF FAILED: "[DT+SITE_NAME] - Output <N> ACTIVE state write ERROR!" (ACK)
4.1 SET OUTPUT ACTIVE STATE	Sets Output <N> Active state <S> High or Low. NB: The default state of any output is Inactive.	Output number N = (1...8) If Active High -> S = 1 If Active Low -> S = 0	IF SUCCESS: "[DT+SITE_NAME] - Output <N> ACTIVE state set to [HIGH or LOW]" (ACK) IF FAILED: "[DT+SITE_NAME] - Output <N> ACTIVE state write ERROR!" (ACK)
E.g.: **password*oact*1*1	ONLY in the most common case of the relay output the user shall take into account the type (NO or NC) of the contact. The default setting is Active High (1) .		
4.2 SET OUTPUT MODE	Sets Output <N> Mode <S> in which it will operate when activated.	Output number N = (1...8) If PULSE Mode S = p If LATCH Mode S = l If TOGGLE Mode S = t	IF SUCCESS: "[DT+SITE_NAME] - Output <N> MODE set to [PULSED or LATCHED or TOGGLED]" (ACK) IF FAILED: "[DT+SITE_NAME] - Output <N> MODE write ERROR!" (ACK)
E.g.: **password*omod*1*1	The default setting is PULSE Mode (p) .		

SMS Command Format + (Example)	Description	Accepted parameters	Response SMS - (ACK) means that response is sent ONLY when sack is set to 1.
4.0 OUTPUT SETUP			
4.3 SET OUTPUT ACTIVE ON TIME **pppppppp'ooont'n'tttt	Sets Output <N> ON Time<T> when activated. Only applicable in PULSE or TOGGLE mode.	Output number N = (1...8) Time T = (1...60000) in increments of 100ms	IF SUCCESS: "[DT+SITE_NAME] - Output <N> ON TIME set to <XXXX>ms!" (ACK) IF FAILED: "[DT+SITE_NAME] - Output <N> ON TIME write ERROR!" (ACK)
E.g.: **password*oont*1*20	The default setting is 1000ms (10) .		
4.4 SET OUTPUT ACTIVE OFF TIME **pppppppp'ooif'n'tttt	Sets Output <N> OFF Time<T> when activated. Only applicable in TOGGLE mode.	Output number N = (1...8) Time T = (1...60000) in increments of 100ms	IF SUCCESS: "[DT+SITE_NAME] - Output <N> OFF TIME set to <XXXX>ms!" (ACK) IF FAILED: "[DT+SITE_NAME] - Output <N> OFF TIME write ERROR!" (ACK)
E.g.: **password*ooft*1*40	The default setting is 1000ms (10) .		
4.5 SET OUTPUT STATE SMS TEXT **pppppppp'ocmd'n's'cccccccccccccccccc cc	Sets the SMS Text string <C> (ONLY received from a VALID USER) that the device will recognise as a command to set Output <N> in State <S>. The Text string is CASE SENSITIVE!	Output number N = (1...8) To change state to Active -> S = 1 To change state to Inactive -> S = 0 Text string C <= 20 characters	IF SUCCESS: "[DT+SITE_NAME] - Output <N> change status to [ACTIVE or INACTIVE] SMS COMMAND message set to <TEXT>!" (ACK) IF FAILED: "[DT+SITE_NAME] - Output <N> change status to [ACTIVE or INACTIVE] SMS COMMAND message write ERROR!" (ACK) NB: Text commands are CASE SENSITIVE!
E.g.: **password*ocmd*1*1*Motor ON	The default setting are: Output <N> ON and Output <N> OFF .		
4.6 SET OUTPUT ALERT SMS OPTION **pppppppp'oal'n's	Sets whether or not a SMS Alert is sent when output <N> state is changed. The alert is sent to ALL Alert Destinations.	Output number N = (1...8) If Alert sent -> S = 1 If Alert NOT sent -> S = 0	IF SUCCESS: "[DT+SITE_NAME] - Output <N> change state SMS ALERT set to [ON or OFF]!" (ACK) IF FAILED: "[DT+SITE_NAME] - Output <N> change state SMS ALERT write ERROR!" (ACK)
E.g.: **password*oal*1*1	The default setting is Alert NOT sent (0) .		
4.7 SEND SMS TEXT WHEN INPUT STATE IS CHANGED **pppppppp'otxt'n's'cccccccccccccccccc	Sets the SMS Text string <C> that the device will send to ALL Alert Destinations when Output <N> changes to State <S>. The default setting are: Output <N> ON and Output <N> OFF .	Input number N = (1...8) If state Active -> S = 1 If state Inactive -> S = 0 Text string C <= 20 characters	IF SUCCESS: "[DT+SITE_NAME] - Output <N> change to [ACTIVE or INACTIVE] state SMS ALERT message set to <TEXT>!" (ACK) IF FAILED: "[DT+SITE_NAME] - Output <N> change to [ACTIVE or INACTIVE] state SMS ALERT message write ERROR!" (ACK)
E.g.: **password*otxt*1*1*Motor started			
4.8 SET OUTPUT TO BE CHANGED BY USER MISSED CALL **pppppppp'ocal'n's	Sets the Output <N> to be triggered or not <S> on a VALID USER incoming call. If the output mode is set to LATCHED, the status of the output will be inverted (if ON -> OFF; if OFF -> ON). If the output mode is set to PULSED, a single pulse will be generated. If the output mode is set to TOGGLE, the status of the output toggling will be inverted (if ON -> OFF; if OFF -> ON). The default setting is Output1 (1) .	Output number N = (1...8) If Triggered on Missed call -> S = 1 If NOT Triggered on Missed call -> S = 0	IF SUCCESS: "[DT+SITE_NAME] - Output <N> change state via MISSED CALL set to [ON or OFF]!" (ACK) IF FAILED: "[DT+SITE_NAME] - Output <N> change state via MISSED CALL write ERROR!" (ACK)
E.g.: **Password*ocal*1*1			
4.9 SET OUTPUT <N> STATE <S> AFTER POWER UP **pppppppp'opup'n's	Sets the SMS Text string <C> that the device will send to ALL Alert Destinations when Output <N> changes to State <S>. The default setting are: Output <N> ON and Output <N> OFF .	Output number N = (1...8) If Active S = 1 If Inactive S = 0 If Last before Power Down S = 2	IF SUCCESS: "[DT+SITE_NAME] - Output <N> Power-Up state set to [ACTIVE or INACTIVE or LAST STATE before POWER DOWN]!" (ACK) IF FAILED: "[DT+SITE_NAME] - Output <N> Power-Up state write ERROR!" (ACK)
E.g.: **password*opup*1*2			

SMS Command Format + (Example)	Description	Accepted parameters	Response SMS - (ACK) means that response is sent ONLY when sack is set to 1.
5- SMS ALERT DESTINATION SET ALERT DESTINATION PHONE NUMBER **pppppppp* <i>aadd</i> *s* <i>ddddd</i> ddddd dd E.g.: ** <i>password</i> * <i>aadd</i> *27739876543	Set Alert Phone number <D> WITH or WITHOUT Site Name <S> for ALL preset SMS alerts. The phone number must be in a valid format. Maximum Alert Destinations: 100.	If Site Name Attached -> S = 1 If Site Name skipped -> S = 0 Phone number D <= 20 digits	IF SUCCESS: "[DT+SITE_NAME] - Alert destination <PHONE_NUMBER> added!" (ACK) IF FAILED: "[DT+SITE_NAME] - Alert destination <PHONE_NUMBER> adding ERROR!" (ACK)
CHECK IF ALERT DESTINATION PHONE NUMBER WAS PREVIOUSLY STORED **pppppppp* <i>achk</i> * <i>ddddd</i> ddddd E.g.: ** <i>password</i> * <i>achk</i> *27739876543	Checks if a particular Phone number <D> is stored as Alert Destination. The phone number must be in a valid format.	Phone number D <= 20 digits	IF SUCCESS: "[DT+SITE_NAME] - Alert destination <PHONE_NUMBER> confirmed!" IF FAILED: "[DT+SITE_NAME] - Alert destination <PHONE_NUMBER> NOT FOUND!"
DELETE PREVIOUSLY STORED ALERT DESTINATION NUMBER **pppppppp* <i>adel</i> * <i>ddddd</i> ddddd E.g.: ** <i>password</i> * <i>adel</i> *27739876543	Deletes previously stored Alert Destination <D>. The phone number must be in a valid format.	Phone number D <= 20 digits	IF SUCCESS: "[DT+SITE_NAME] - Alert Destination <PHONE_NUMBER> deleted!" (ACK) IF FAILED: "[DT+SITE_NAME] - Alert Destination <PHONE_NUMBER> write ERROR!" (ACK)
6- SMS REPORT DESTINATION GET DEVICE STATUS REPORT **pppppppp* <i>rsta</i> E.g.: ** <i>password</i> * <i>rsta</i>	Solicits a Status report from the unit via SMS. The device shall ONLY respond to the	N/A	IF SUCCESS: <Text string containing: Site name; IMEI; Cell number; Network operator; FW version; HW version; Power supply voltage; LPV level; GSM signal; Number of Users; Number of Report destinations; Number of Alert destinations>
GET SIM BALANCE REPORT **pppppppp* <i>rbal</i> E.g.: ** <i>password</i> * <i>rbal</i>	Queries the balance on the SIM card via SMS. The unit solicits the balance values from the network via USSD and sends an exact replication of the text string back to the destination from which the query originated.	N/A	IF SUCCESS: [DT+SITE_NAME] - <USSD text string containing balance as received from the Network operator>
SET REPORT DESTINATION PHONE NUMBER **pppppppp* <i>radd</i> * <i>ddddd</i> ddddd E.g.: ** <i>password</i> * <i>radd</i> *27739876543	Set Report Destination Phone number <D> for periodic SMS reports. The phone number must be in a valid format. Maximum Report Destinations: 10.	Phone number D <= 20 digits	IF SUCCESS: "[DT+SITE_NAME] - Report destination <PHONE_NUMBER> added!" (ACK) IF FAILED: "[DT+SITE_NAME] - Report destination <PHONE_NUMBER> write ERROR!" (ACK)
CHECK IF REPORT DESTINATION NUMBER WAS PREVIOUSLY STORED **pppppppp* <i>rchk</i> * <i>ddddd</i> ddddd E.g.: ** <i>password</i> * <i>rchk</i> *27739876543	Checks if a particular Phone number <D> is stored as Report Destination. The phone number must be in a valid format.	Phone number D <= 20 digits	IF SUCCESS: "[DT+SITE_NAME] - Report destination <PHONE_NUMBER> confirmed!" IF FAILED: "[DT+SITE_NAME] - Report destination <PHONE_NUMBER> NOT FOUND!"
DELETE PREVIOUSLY STORED REPORT DESTINATION NUMBER **pppppppp* <i>rdel</i> * <i>ddddd</i> ddddd E.g.: ** <i>password</i> * <i>rdel</i> *27739876543	Deletes a previously stored Report Destination <D>. The phone number must be in a valid format.	Phone number D <= 20 digits	IF SUCCESS: "[DT+SITE_NAME] - Report destination <PHONE_NUMBER> deleted!" (ACK) IF FAILED: "[DT+SITE_NAME] - Report destination <PHONE_NUMBER> delete ERROR!" (ACK)
SET REPORT TIME **pppppppp* <i>rtim</i> * <i>tttttt</i> E.g.: ** <i>password</i> * <i>rtim</i> *24h00m	Sets the Interval <T> (in XXhXXm format) at which the unit will automatically send a Status Report (as described in repsta command) to ALL Report Destinations. The default is 00h00m (disabled).	Time T = (XXhXXm) in increments of 1min XXh <= 99 hours XXm <= 59 minutes	IF SUCCESS: "[DT+SITE_NAME] - Report interval set to 24 hours!" (ACK) IF FAILED: "[DT+SITE_NAME] - Report interval change ERROR!" (ACK)

CONTENTS IN BOX



Instruction Leaflet



X2

Fasteners kit

1x **MELINK-IT2-01**
Sentry™ GSM Communicator 1 input + 1
output with onboard antenna.
(**MELINK-IT2-02** is supplied with an
external antenna)

WEB SITE

www.martin-electronics.co.za



APP STORE

MY SENTRY PRO



CONTACT DETAILS:

POSTAL ADDRESS:
PO BOX 82129
SOUTHDALE
JOHANNESBURG
2135
SOUTH AFRICA

TEL: +2711 433 4084
FAX: +2711 680 3080

TECH SUPPORT:
technical@martin-electronics.co.za

WEBSITE: www.martin-electronics.co.za

TRADING HOURS:
MONDAY - THURSDAY 8:00 - 17:00 CAT
FRIDAY: 8:00 - 16:00 CAT

FACEBOOK

@sentryremotes



YOUTUBE CHANNEL

@sentrymartinelectronics

